

BFF40P, BFF60P, BFF80P, BFF110P



- ▶ Special designed friction cups for oily surfaces, such as sheets in metal forming processes.
- ▶ Normal wear on friction cup will not affect the long term shear force performance.
- ▶ Best choice if $> 0,1\text{g}/\text{m}^2$ press oil is used on the sheet.
- ▶ Thanks to the strong grip on oily surfaces, the suction cups can withstand high shear forces, typically 2–4 times more than corresponding conventional suction cups.
- ▶ The "BFF" design is suitable for uneven/curved surfaces or if level compensation is needed, for example in de-stacking applications.
- ▶ The flat inner support gives stability during movement in any orientation.
- ▶ DURAFLEX® suction cups manufactured in a specially developed material that features the elasticity of rubber and wear resistance of polyurethane. The material does not leave any marks on the objects handled.

LIFTING FORCES & TECHNICAL DATA

Model	Material to be handled	Lifting forces vertical to the surface, N, at vacuum level		Friction/shear forces parallel to the surface, N, at vacuum level		Volume cm ³	Min. curve radius mm	Weight g
		60 -kPa	90 -kPa	60 -kPa	90 -kPa			
BFF40P	Oily steel plate	45	60	35	45	10	23	20–34
BFF60P	Oily steel plate	82	106	76	93	20	35	30–58
BFF80P	Oily steel plate	174	207	110	160	50	50	66–96
BFF110P	Oily steel plate	284	345	235	253	110	95	160–178

Values valid for steel sheet with surface finish Ra 1 and 2-3g/m² of press oil.

MATERIAL SPECIFICATIONS

Material	Colour	Hardness, °Shore A	Temperature range, °C
Polyurethane, PU55	Orange	55	10–50
Polyurethane, PU60	Green transparent	60	10–50

MATERIAL RESISTANCE

Wear resistance	Oil	Weather & ozone	Hydrolysis	Petrol	Concentrated acids	Ethanol	Methanol	Oxidation
Excellent	Excellent	Excellent	Fair**	Fair	Fair**	Fair	Poor	Poor

**Please contact PIAB.

ORDERING INFORMATION

	Complete suction cups	Code	Art. No.
A	Suction cup BFF40P Polyurethane 55/60, G3/8" male, with mesh filter	BFF40P.4R.04UF	0118991
B	Suction cup BFF40P Polyurethane 55/60, G3/8" female	BFF40P.4R.04UA	0118992
B	Suction cup BFF40P Polyurethane 55/60, 3/8" NPSF female	BFF40P.4R.04UB	0118993
C	Suction Cup BFF40P Polyurethane 55/60, M10 male	BFF40P.4R.M10M	0121427
A	Suction cup BFF60P Polyurethane 55/60, G3/8" male, with mesh filter	BFF60P.4R.06UF	0118994
B	Suction cup BFF60P Polyurethane 55/60, G3/8" female	BFF60P.4R.06UA	0118995
B	Suction cup BFF60P Polyurethane 55/60, 3/8" NPSF female	BFF60P.4R.06UB	0118996
C	Suction cup BFF60P Polyurethane 55/60, M10 male	BFF60P.4R.M10M	0121428
A	Suction cup BFF80P Polyurethane 55/60, G3/8" male, with mesh filter	BFF80P.5R.G45M	0118997
B	Suction cup BFF80P Polyurethane 55/60, G3/8" female	BFF80P.5R.G45W	0118670
B	Suction cup BFF80P Polyurethane 55/60, 3/8" NPSF female	BFF80P.5R.N45W	0118669
C	Suction cup BFF80P Polyurethane 55/60, M10x1.5 male	BFF80.5R.M10M	0121384
A	Suction cup BFF110P Polyurethane 55/60, G3/8" male, with mesh filter	BFF110P.5R.G45M	0118671
B	Suction cup BFF110P Polyurethane 55/60, G3/8" female	BFF110P.5R.G45W	0118673
B	Suction cup BFF110P Polyurethane 55/60, 3/8" NPSF female	BFF110P.5R.N45W	0118672
C	Suction cup BFF110P Polyurethane 55/60, M10 male	BFF110P.5R.M10M	0121430

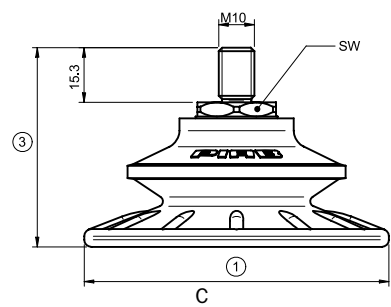
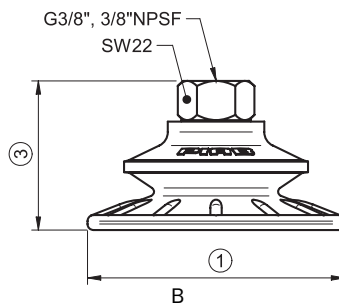
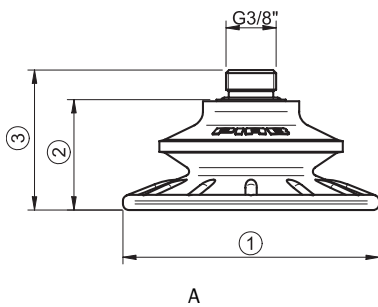

Measures complete suction cups	BFF40P			BFF60P			BFF80P			BFF110P		
	A	B	C	A	B	C	A	B	C	A	B	C
1	45	45	—	61	61	—	85	85	—	115	115	—
2	22	—	—	26	—	—	37	—	—	53	—	—
3	32	32	51.5	36	36	55.3	46	50	55.8	63	66	72.3
Max. vertical movement, mm	7	7	7	10	10	10	14	14	14	21	21	21
Max. expanding lip, mm	46	46	46	62	62	62	87	87	87	118	118	118
Wrench size SW	—	22	24	—	22	24	—	22	22	—	22	22